

# WHEEL STUDS & NUTS

AL-KO wheel studs are all fitted using a knurled section that stops the stud from rotating. Always ensure that only quality studs and nuts are used, which are correct for the wheel selected.

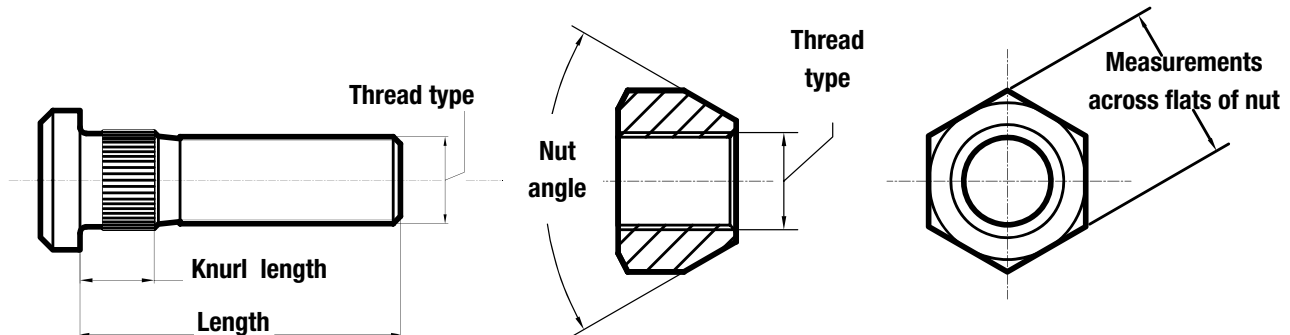

## WHEEL STUDS

Part No.	Description	Thread Type & Size	Length From Under Head	Nominal Hole Diameter	Knurl Length From Under Head
490200	7/16" UNF short knurl	7/16" UNF	41mm	13.5mm	5mm
490205	Plated 7/16" UNF short knurl	7/16" UNF	41mm	13.5mm	8mm
490300	1/2" UNF short knurl	1/2" UNF	41mm	13.5mm	9mm
490301	1/2" UNF short knurl industrial	1/2" UNF	51mm	15.5mm	11mm
490301PL	Plated 1/2" UNF short knurl industrial	1/2" UNF	51mm	15.5mm	11mm
490302	1/2" UNF long knurl industrial	1/2" UNF	57mm	15.5mm	21mm
490305	Plated 1/2" UNF Short knurl	1/2" UNF	41mm	13.5mm	9mm
490358	Plated M12 short knurl	M12 x 1.5	41mm	13.5mm	5mm
490340	M14 x 50mm short knurl	M14 x 1.5	50mm	15.5mm	11mm
490345	M14 x 58mm long knurl	M14 x 1.5	58mm	15.5mm	23.5mm
490357PL	Plated M12 short knurl industrial	M12	51mm	15.5mm	11mm
490400	9/16" UNF short knurl	9/16" UNF	50mm	15.5mm	12mm
490401	9/16" UNF long knurl	9/16" UNF	57mm	15.5mm	22mm
490402	9/16" UNF short knurl – for 5 stud L/Cruiser	9/16" UNF	50mm	15.5mm	12mm
490501	5/8" UNF long knurl	5/8" UNF	57mm	17.5mm	22mm
490502	5/8" UNF special – short knurl R/Rover 10" Electric	5/8" UNF	51mm	17.5mm	12mm
490600	7/8" BSF short knurl	7/8" BSF	63mm	23.5mm	17mm
490601	7/8" BSF long knurl	7/8" BSF	70mm	23.5mm	23mm

## WHEEL NUTS

Part Number	Description	Thread Type and Size	Nut Angle	Measurement Across Flats of Nut
490251	7/16" UNF x 60°	7/16" UNF	60°	19mm
490350	1/2" UNF x 60°	1/2" UNF	60°	20.5mm
490355	M12 x 60°	M12	60°	19mm
490451	9/16" UNF x 80°	9/16" UNF	80°	23.8mm (15/16")
490460	9/16" UNF x 60° – for 5 stud L/Cruiser	9/16" UNF	60°	22mm
490551	5/8" UNF radius	5/8" UNF	Radius	25.4mm (1")
490650	7/8" BSF	7/8"BSF	80°	31.75mm (1.25")